

DEVELOPMENT OF A PLATFORM FOR SUPPORTING DESIGN FOR ENVIRONMENT

Srinivas Kota¹ and Amaresh Chakrabarti¹

¹IdeaSLab, Centre for Product Design and Manufacturing, Indian Institute of Science, Bangalore, India

ABSTRACT

Individual guidelines often exist for DfE but these are not integrated with design tools. There is no comprehensive method that can be useful for the whole life cycle of a product in various stages of its design. Few tools exist that could aid iterative changes to a design required in product development and there is a need for an integrated methodology and computational support for designers. Life Cycle Assessment (LCA) [1] is arguably the most promising and scientifically defensible method for estimating environmental impacts of a product during its lifecycle [2]. Like DfE guidelines, LCA tools are not well integrated with design process and tools. Consequently, there is a need for an LCA tool integrated into the natural design process that can be applied to early as well as detailed design stages.

A new integrated platform [3] has been developed, and proposed in this paper for supporting synthesis in product development on a commercial CAD workspace, while also aiding automated capture and storage of the rationale behind the decisions, for retrieval whenever required during design. This platform is now extended to support analysis of product proposals created so as to automatically extract the information already stored while designing and ask for other information required to model the lifecycle with minimal extra effort from the designer. Evaluation using two designers solving two design problems with the aid of the new platform and without its aid but with the aid of existing tools indicated improvement in design and designer performance as a result of using the new support.

Keywords: design for environment, life cycle design, Ecodesign, life cycle assessment, life cycle thinking, early phases of design

1 INTRODUCTION

Individual guidelines often exist for DfE but these are not integrated with design tools. There is no comprehensive method that can be useful for the whole life cycle of a product in various stages of its design. Few tools were found which could aid the iterative process of change required in product development, and there is need for an integrated methodology and computational support for designer.

Life Cycle Assessment (LCA) [1] is the most promising and scientifically proven method for estimating environmental impacts of a product during its lifecycle [2]. Like individual DfE guidelines, LCA tools are also not well integrated with design process and tools. Consequently, there is a need for an LCA tool integrated into the natural design process that can be applied to early as well as detailed design stages.

2 OBJECTIVES AND METHODOLOGY

The following are the objectives of this research:

1. Identify current DfE tools and evaluate their applicability to early as well as detailed design stages, while being integrated to the typical design process. This is carried out using literature survey.
2. Identify the typical design process followed by designers, and understand the behaviour and requirement of the designer that need to be supported or taken into account for DfE. This is done through descriptive studies of designers and literature search.

3. Develop an integrated platform for product development and analysis for DfE using LCA methodology. This is carried out by developing a computer support and evaluating this support using designers.

3 LITERATURE SURVEY

Environmental considerations should be integrated into the product development process, in the same sense as quality, cost, safety etc. The lifecycle principle is about considering the impact of a product across its whole life cycle, from 'cradle to grave'. Eco-efficient improvements in some cases are swallowed up by increased sales or personal levels of consumption and by the 'rebound' effect – where resource savings are cancelled out by an increase in resource use elsewhere. We ***need to integrate environmental considerations as early as possible in design***, into the project brief or at idea generation stage to get maximum environmental benefit in products [4]. To be able to design more environmentally friendly products, a very important factor is time - to be able to reconsider an idea to develop new concepts for evaluation. Another issue is optimizing the current parts in a product [5].

There is a need to make many critical decisions before the specification for a product is fixed. Few tools were found which enabled the ***iterative changes*** required in product development, and this is an area which needs further research. Understanding of the trade-offs available between different product life-cycle phases is a must for developing environmental friendly products [6]. Showing the ***history*** behind or the intention during a judgement helps another person understand the perspective [7].

Product development has traditionally been directed to balancing technical performance against economy for producer and customer. Now is the extended time scale where manufacturers have to consider environmental impact and producer's responsibility over the products' entire life cycle. Several industrial cases showed that environmental consideration in product and process development at the same time means improved economy. ***Development of simplified and easy-to-use methods and environmental indicators to be used by designers is required*** [8].

A variety of methods and tools have been developed for DfE, such as Quality Function Deployment for Environment (***QFDE***) [9], Environmental Effect Analysis (***EEA***) [10], Ecological classification and risk analysis (***ECRA***) [11], and Quality in Environment Function Deployment (***Qefd***) [12] to support the ***early stage of product development*** with high degree of freedom of design. They work with low quality of data, are easy to learn and require little time.

Tools developed such as ***DfE workbench*** [13], ***Life Cycle Modelling*** [14], ***Oil Point Method*** [15], and ***Life Cycle Assessment*** (LCA) [1] are useful in the ***later stages of the product development*** where most of the options are already decided. They require lot of data, time and effort from the designer.

Methods developed for specific life cycle phases such as for the ***usage phase*** [16], ***Design for Energy Efficiency*** (DfEnEf) [17], integration method for ***recycling*** [18], and ***Recycling Data Management System*** (ReDaMa) [19] caters for the need for specific life cycle phases.

Tools developed by combining different other tools like Ecodesign PILOT and QFDE have been reported to encourage better results [20]. There is, however, a need to develop ecodesign tools that would be more appropriate to the working practices of industrial designers. Industrial designers need tools that are more appropriate to ***their*** way of working [21].

The requirements of the designer for better support for DfE according to [22] are: tools should be proactive, easy to learn, understand and use, should allow understanding of design rationale, act as a checklist, reduce total time, store knowledge and experience as know-how backup, should be useful in all stages of design, should not require extra effort for analysis, should be integrated to CAD, should aid in trade off between choices, show uncertainty analysis, contain standards & regulations, aid in analysis & improvement, and consider all lifecycle phases.

Tools like QFDE, EQFD, ECRA, EEA and checklists are useful in the conceptual stage of the design and are qualitative in the nature. Tools like Life Cycle Modelling, LCA, and DFE workbench [13] are useful in the detailed stages of design and are quantitative.

However, most of the current tools lack in the following designer requirements for a DfE tool: allow to understand design rationale, act as checklist, reduce the risk of forgetting important elements in product development, store knowledge and experience as know-how backup, be useful in all stages of design, aid in trade off between choices, show uncertainty analysis, and contain standards & regulations. There is a need of studying the typical activities performed by designers in the process of design. The next section is going to describe the exercises and analysis done in this regard.

4 DESIGN EXPERIMENTS

A review of contemporary literature and analysis of the design experiments helped us identify the typical design processes followed by designers. A series of three design experiments was conducted in order to obtain a general understanding of the design process as well as to investigate the changes in the situation with the availability of information or support for DfE. This is explored through descriptive studies of designers solving design problems with increasing amount of information and support available on DfE. This is also used to understand the specific constraints associated with using information or support for DfE, to better clarify support development needs.

4.1 Design Experiments Plan

Three Design Experiments are conducted in order to validate the need for a support for Design for Environment (DfE) by finding answers to the following questions:

- Whether designers generally consider environment as an important criterion in designing.
- Whether this consideration is bettered by the existence of information or support for DfE.
- What aspects of general designing must be taken into account while developing support for DfE?

Table 1 shows the plan and context of the three design experiments. Table 2 shows the result of comparison of the three experiments on the criteria of environmental consciousness of designers and effectiveness of the support provided in each. We observed the following results:

- Designers in general are not aware of environmental impact as a criterion
- It is possible to estimate impact during early stages of design.

Table 1 Plan of three design experiments

Experiment No 1	Experiment No 2	Experiment No 3
Give Problem	Give Problem	Give Problem
Give literature related to Design	Give literature related to Design and DfE	Give literature and Detailed Impact Assessment Software
Capture whole Design Process by video	Capture whole Design Process by video	Capture whole Design Process by video
Take Design Documentation	Take Design Documentation	Take Design Documentation
Give brief explanation of Product Life Cycle Stages	Give brief explanation of Product Life Cycle Stages and DfE	Give brief explanation of the software (current) available and ask subjects to use it if they feel necessary

- *Experiment 1* is to obtain understanding of the general design procedure and general environmental consciousness of the designers.
- *Experiment 2* relative to *Experiment 1* is to understand the effects of environmental information supplied in terms of books.
- *Experiment 3* relative to *Experiment 2* is to understand the effects of detailed impact assessment software (current).

Table 2 Comparison of design experiments

Criteria	Experiment No 1	Experiment No 2	Experiment No 3
Environmental consciousness	Not aware	Aware but felt difficult in finding the information	Aware and used the software for finding EI and reducing it by modifying design
Effectiveness		Not effective because tedious to browse and search	Effective but after detail design

4.2 Main design stages

The following main design stages were observed with respect to time:

4.2.1 0 – 15 % of design time:

Here requirements of the design are specified. Table 3 shows a part of the transcription from the task clarification phase from one of the design experiments, where the subject is specifying the requirements. The first column specifies the time (seconds), second column shows the designer code and the third column is the designer's utterances verbatim.

Table 3 Part of the transcription in the task clarification phase

time	person	transcription
7.44	S1	privacy is not there in gymnasium
7.52	S1	privacy is not there means lot of people are feeling, feeling what
8.03	S1	feeling shy of going there, body building exercise probably
8.09	S1	why they don't do exercise wearing the full dress (smile) strange
8.15	S1	current equipment occupies lot of space ok
8.28	S1	and usually are not portable
8.34	S1	these are problems with current equipment
8.39	S1	so the requirements are external requirements, some are constraints
8.46	S1	apart from the solution of the problem, requirements are that
8.52	S1	it should be easily setupable
9.07	S1	it should be setup easily and portable
9.12	S1	and should help in complete workout of the body
9.27	S1	ya
9.29	S1	first of all the thing is that whether we really achieving that

4.2.2 15 – 40 % of design time:

In this phase, ideas, preliminary spatial layouts and sub-assemblies are specified. Figure 1 shows the sketch of an assembly 'handle' at one particular time in the conceptual stage.

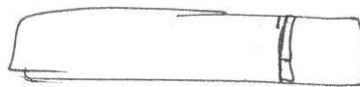

Figure 1 Sketch of an assembly 'handle' in the conceptual stage

4.2.3 40 – 80 % of design time:

In this phase, interface details of sub systems were specified. Figure 2 shows the sketch of an assembly 'handle' in the embodiment stage.

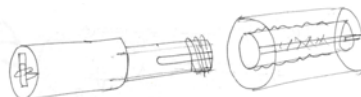

Figure 2 Sketch of an assembly 'handle' in the embodiment stage (exact reproduction of sketch)

4.2.4 80-100 % of design time:

Here detailed dimensions, materials and manufacturing tolerances are specified. Figure 3 shows the detailed drawings of one component of the 'handle' in the detailed design stage.

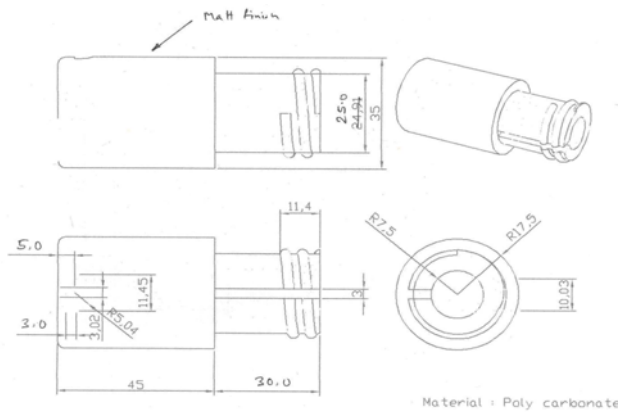

Figure 3 Final drawing of one component of the 'handle' in detailed design stage (exact reproduction of drawing)

The activities performed by the designer and the resulting information are discussed in the next two sections.

4.3 Activities performed by designer

The types of activity performed by a designer as observed during a design process are listed below. The intended support should allow a designer to do the above activities with ease and in a short time.

4.3.1 Product version definition:

It is the specification of a concept. For example, the designer in an experiment sketched four sketches first and then said that these together constitute his first version of the product. After modifying and deleting some of these sketches and evaluating them, he reduced these to three assemblies and said this was his second version. Figure 4 shows the version definitions as sketched by the designer.

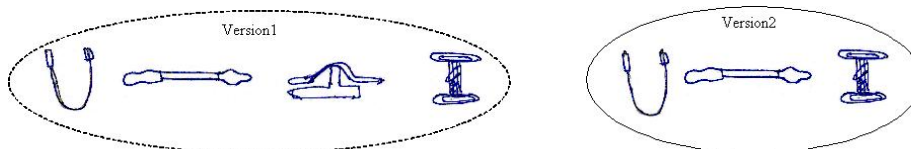

Figure 4 Version definition (exact reproduction of sketch)

4.3.2 Addition and subtraction of physical objects/information:

This entails addition or removal of components or features from an existing assembly or component. For example, the designer in Figure 6 first drew a skipping rope and to this he added two foot-clamps, see Figure 5. This figure shows the activity of adding components to an earlier assembly. Figure 6 shows the activity of material addition to a component.

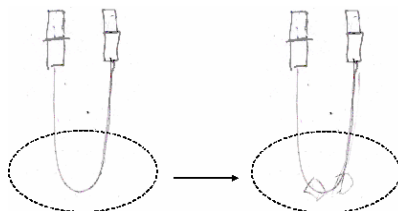

Figure 5 Component addition

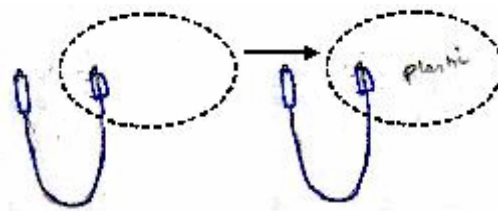

Figure 6 Material addition

4.3.3 Addition and subtraction of relationships between objects:

In this activity, relationships between objects are specified or removed. For example, the designer in Figure 7 initially drew the two boxes attached without specifying any relationship between them (left of the figure). After this, he added the detail of how the components were exactly related (right of the figure). Figure 7 shows this activity of addition of relation (thread) between the two parts of the handle assembly.

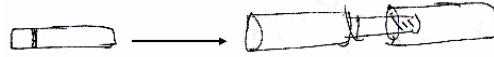

Figure 7 Relation addition (exact reproduction of sketch)

4.3.4 Substitution of object/information:

This activity is a combination of two activities; subtraction of already available object/information and addition of new object/information. For example, in a single activity, the designer in Figure 8 removed the rope and modified the handle part. Figure 8 therefore shows the substitution of an object (rope).

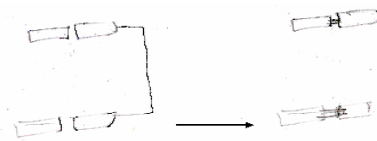

Figure 8 Substitution of objects (exact reproduction of sketch)

4.3.5 Focus to object or information:

In this activity, a designer concentrates on a particular object or information. For example, while designing workout equipment for executives, the designer in Figure 9 drew a sketch representing a skipping rope with handles. In the next sketch, he drew only the handles without drawing the rope because he wanted to focus on the handle. Figure 9 shows this focus activity.

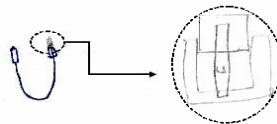

Figure 9 Focus to object (exact reproduction of sketch)

4.3.6 Defocus from object or information:

Here a designer defocuses, from a focused object or information, by representing the outline. For example, in a defocus activity, the designer in Figure 10 sketched the details of the handle and then the outline of the handle.

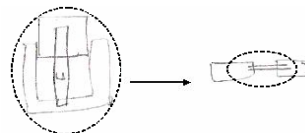

Figure 10 Defocus from object (exact reproduction of sketch)

4.3.7 Change of the view or focus:

This activity is a combination of two activities; defocusing from the already focused object/information and focusing on others. For example the designer in Figure 11 was initially interested on the internal object (spring) within a rope assembly. Afterwards he changed his point of interest to the outside object (casing).

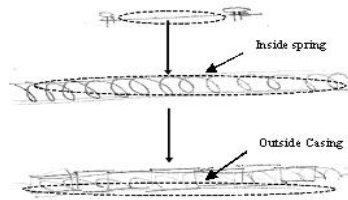

Figure 11 Change of focus (exact reproduction of sketch)

4.3.8 Change of orientation of the objects:

Here, a given object is orientated in a different way as a result of the activity. For example, the designer in Figure 12 initially sketched the object vertically and then changed this to be horizontal.

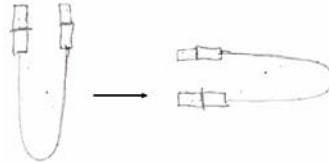

Figure 12 Object rotation (exact reproduction of sketch)

There are some activities that are spoken only, and cannot be represented using drawings or as associations between objects with information. There should be some mechanism for capturing these activities, while allowing a designer to do the activities fast and with ease. We found that **current support is inadequate in terms of integrated, sustainable product development where design and impact estimation are seamlessly integrated**. The need to develop a computer-based method using which a designer will be able to create alternative product proposals, choose their alternative possible lifecycle processes and evaluate the overall impact of each proposal for such choices, at various stages of product development, with various degrees of completeness and detail of the product is highlighted.

5 TOOL DEVELOPMENT

A new integrated platform [3] is developed, and proposed in this paper for supporting synthesis in product development on a commercial CAD workspace, while also aiding automated capture and storage of the rationale behind the decisions for retrieval whenever required during design. This platform is now extended to support environmental impact analysis of product proposals created by automatically extracting information already stored while designing and asking for other information required to model the lifecycle, with minimal extra effort from the designer. It then uses a method for uncertainty reasoning developed in [24] to estimate the level of confidence on the impact value owing to the incompleteness in information available. The estimation is possible at component, assembly or product levels, for a single lifecycle stage or multiple stages. For impact estimation, we used Ecoindicator99 methodology as the basis. The overview of the implemented prototype is shown in Figure 13. It consists of 6 modules which are given in the figure below.

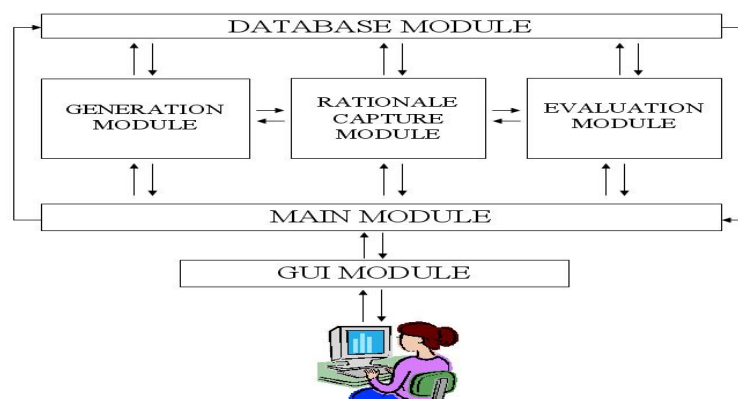

Figure 13 Overview of IDEA-SUSTAIN

Figure 14 shows a screenshot of the main GUI for the developed tool IDEA-SUSTAIN. In this figure we can see the version tree created during a specific design session. A version tree consists of snaps and events, where each snap consists of the product structure at a state of the product, and other snap properties. Details regarding version tree, snaps, events etc can be found in [3].

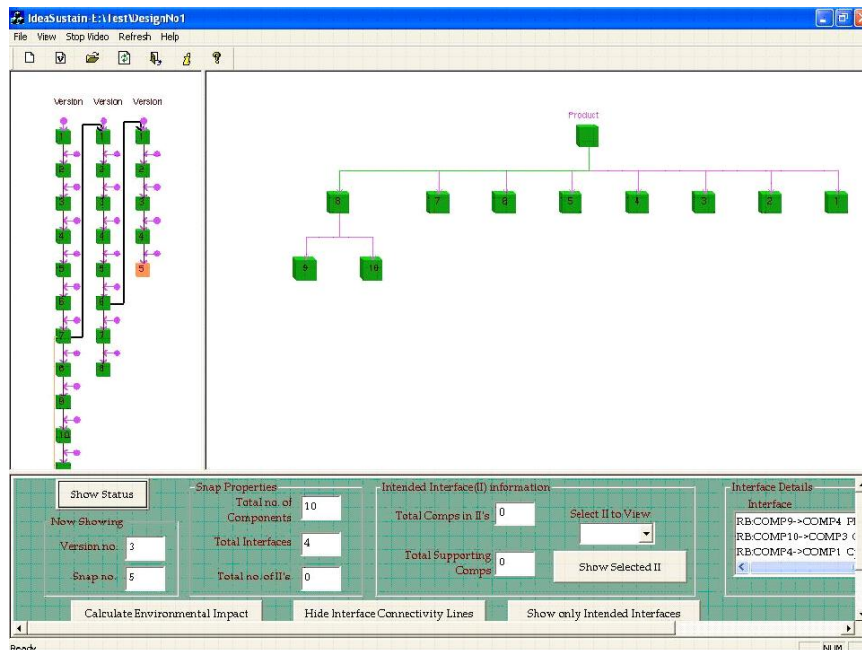

Figure 14 Version tree and Product Structure with information

Figure 15 shows the event window where an event - the proceedings between two snaps captured are played for review of rationale.

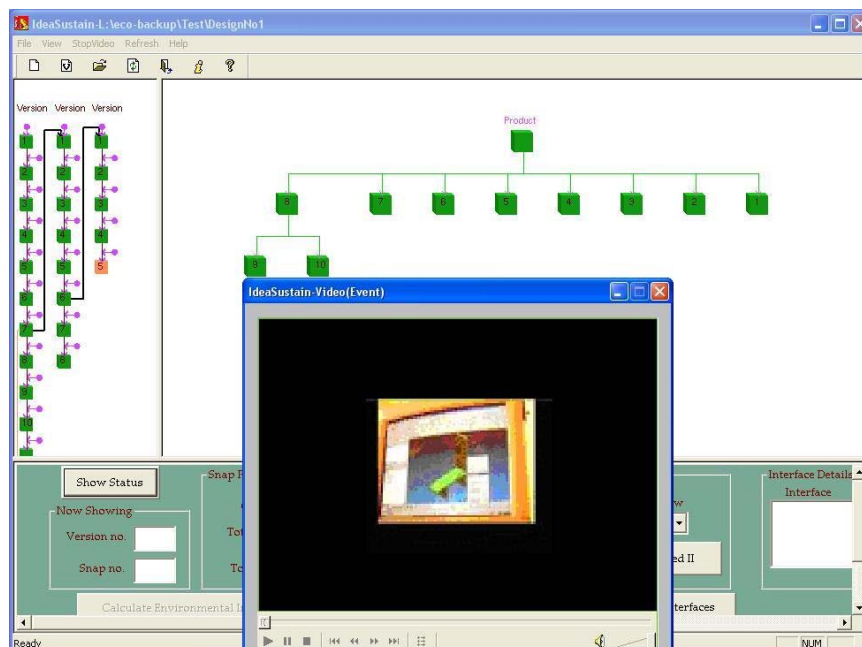

Figure 15 Viewing of event between the snaps

Figure 16 shows the assembly of a product proposal developed using a CAD software within the tool.

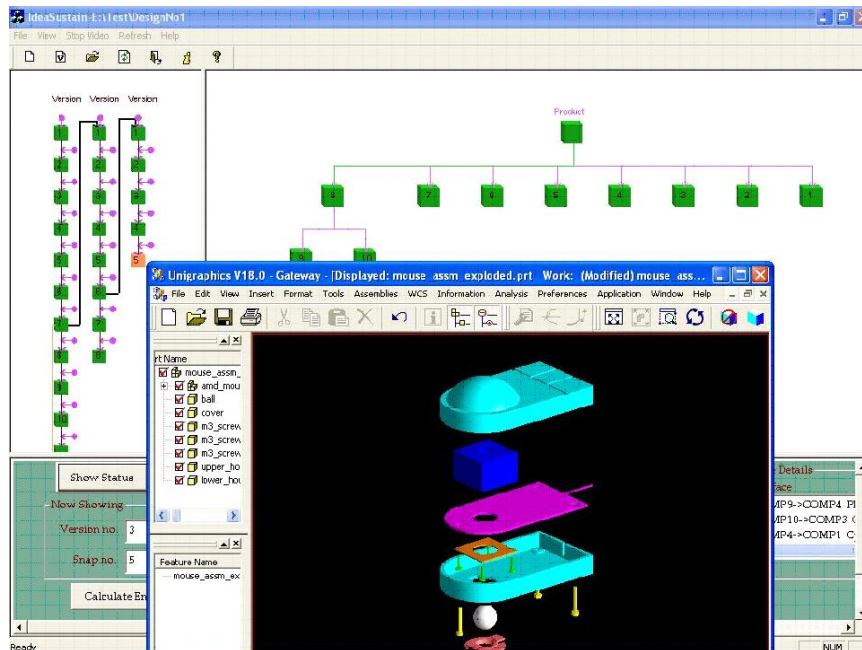

Figure 16 Product model in CAD software

Snaps and events were created depending on the rules framed based on the analysis of the previous section. Whenever designer wants environmental impact analysis to be carried out, she can select the particular snap that captures the structure of the product intended to be evaluated, and ask for analysis. Figure 17 shows the life cycle information window, which consists of automatically captured information taken from the CAD model and asks for other life cycle information not given before.

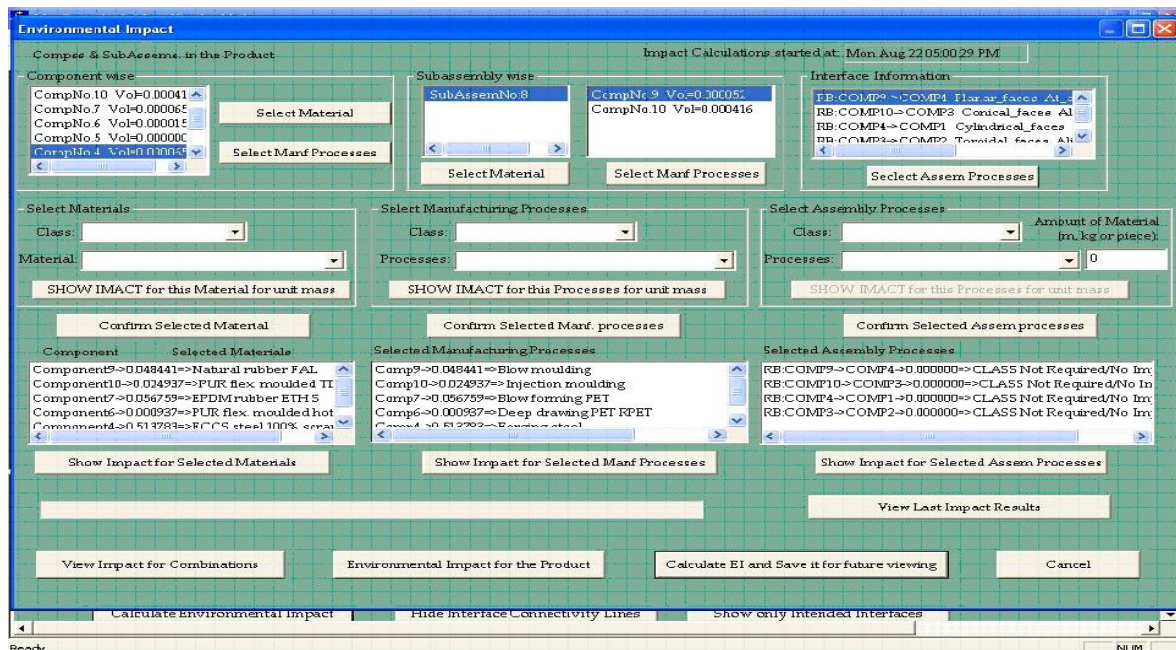

Figure 17 Input window for life cycle information

After gathering the information required, impact can be calculated and viewed for a particular life cycle stage, component, assembly, product or total life cycle. Figure 18 shows the individual and integrated impact of a product proposal on human health, ecosystem quality, resources. Figure 19 shows the damage values, normalized values, overall score and overall confidence on the overall score. Figure 20 shows comparison of impact of different product proposals, using an approximation calculation method [see 24].

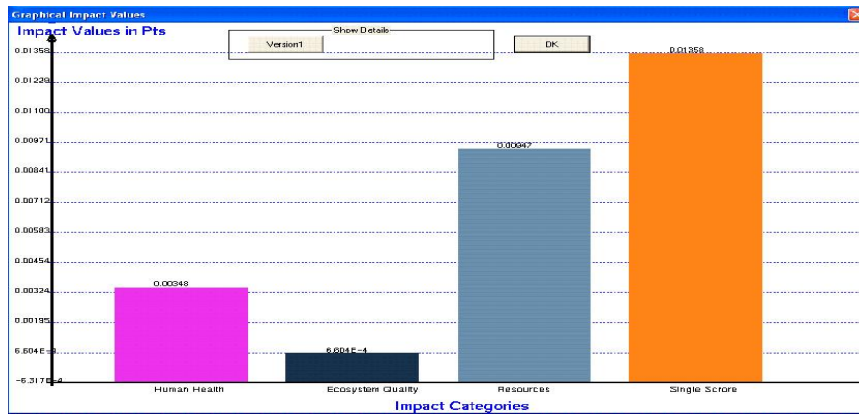

Figure 18 Impact values

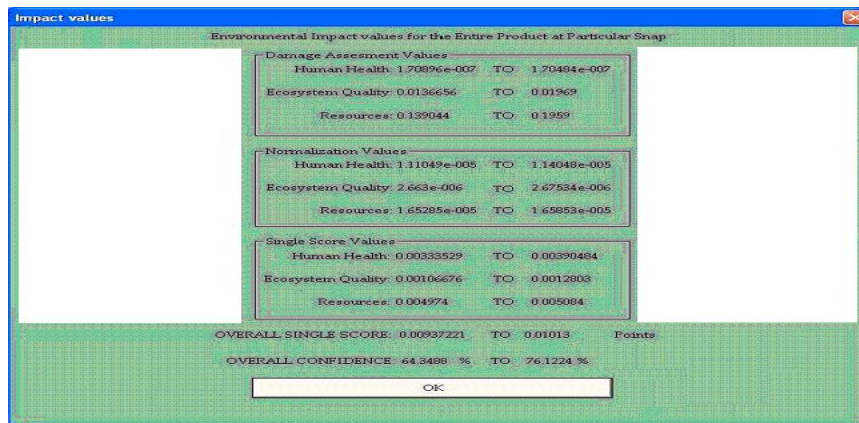

Figure 19 Impact values with overall confidence

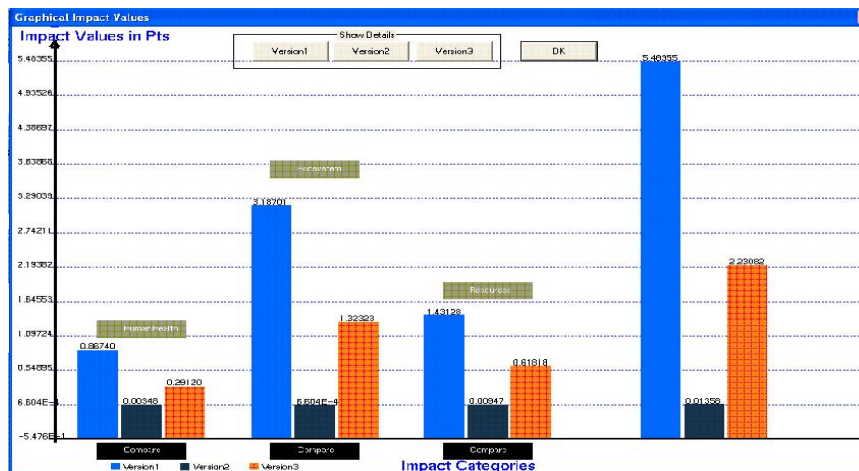

Figure 20 Comparison of different product proposals

6 EVALUATION

Evaluation using two designers solving two design problems with the aid of the new platform and without its aid but with the aid of existing tools indicated improvement in design and designer performance in terms of the number of solution alternatives explored, percentage of time involved in exploration (generation and evaluation), and average impact of the solutions selected as a result (less using the new method). See Table 4 for the comparison. The tool is being extended for inclusion of environmental friendly design strategies for improvement in the initial stages and the other requirements like aiding in trade-off between choices, acting as a checklist, and reducing the risk of forgetting important elements specified by the designers.

Table 4 Evaluation of the support developed

Sl. No.	Criteria	S1 (w/o)	S2 (w/o)	S1 (with)	S2 (with)	Comments
1	Problem Number	P1	P2	P2	P1	
2	Total no of concepts	2	2	4	3	More no of concepts generated
3	EI of final concept	2.28Pt	1.95Pt	2.44Pt	0.73Pt	Average EI with new software (1.59Pt) less than average EI without using new software (2.11Pt)
4	Confidence	--	--	67.36%	100%	Confidence on the impact value is known with software
5	% time in idea generation	34.24	36.76	35.5	19.14	Less %time spent in producing more concepts
6	% time in EI Evaluation	10.95	10.29	6.2	5.1	Less %time spent in EI evaluation of more concepts

7 CONCLUSION AND FUTURE WORK

We reviewed a number of current DfE tools and evaluated their applicability to early as well as detailed design stages, as well as their status of integration into the design process. We also identified the typical design processes followed by designers, and established the behaviour and requirement of designers that should be supported or taken into account for DfE. We then developed an integrated platform for product development and analysis for DfE using LCA for impact assessment, and evaluated this support using designers. This gave better performance compared to existing LCA tools.

REFERENCES

- [1] Frank Consoli et. al., *Guidelines for Life-Cycle Assessment: A 'Code of Practice'*, 1993 (SETAC, Brussels).
- [2] Joost F. P., Design for Environment in practice, In *International Conference on Engineering Design, ICED '97, Vol.3*, Tampere, August 1997, pp.611-616. (Tampere University of Technology, Tampere)
- [3] Amaresh Chakrabarti, Srinivas Kota, Nageshwar Rao, Sekhar Chowdary, A Designer Workbench with Real-Time Capture and Reuse of Information on Product Evolution and Rationale, In *International Conference on Engineering Design, ICED '05*, Melbourne, August 2005. (Institution of Engineers, Australia)
- [4] Chris Sherwin and Tracy Bhamra, Beyond Engineering: Ecodesign as a proactive approach to product innovation, In *First International Symposium on Environmentally Conscious Design and Inverse Manufacturing, Ecodesign '99*, Tokyo, December 1999, pp. 41-46.
- [5] Akermark Anne-Marie, Design for Environment from the Designers perspective, In *First International Symposium on Environmentally Conscious Design and Inverse Manufacturing, Ecodesign '99*, Tokyo, December 1999, pp. 47-50. (IEEE Computer Society, Los Alamitos).
- [6] McAloone T C. and Evans S., Using Empirical Data To Build An Advisory Tool For Eco-Design, In *First International Symposium on Environmentally Conscious Design and Inverse Manufacturing, Ecodesign '99*, Tokyo, December 1999, pp.52-55.
- [7] Toshiharu Taura, Why does the environmental problem occur? – A discussion that focuses on defect in human knowledge, In *First International Symposium on Environmentally Conscious Design and Inverse Manufacturing, Ecodesign '99*, Tokyo, December 1999, pp.56-60.
- [8] Jan-Gunnar Persson, Dematerialisation – Some Implications on Product Design, In *First International Symposium on Environmentally Conscious Design and Inverse Manufacturing, Ecodesign '99*, Tokyo, December 1999, pp.61-66. (IEEE Computer Society, Los Alamitos).

- [9] Keijiro Masui, Tomohiko Sakao and Atsushi Inaba, Quality Function Deployment for Environment: QFDE (1st Report) – A methodology in Early Stage of DfE, In *Second International Symposium on Environmentally Conscious Design and Inverse Manufacturing, Ecodesign '01*, Tokyo, December 2001, pp.852-857. (IEEE Computer Society, Los Alamitos).
- [10] Mattias Lindahl, Environmental Effect Analysis – How does the method stand in relation to lessons learned from the use of other design for environment methods, In *Second International Symposium on Environmentally Conscious Design and Inverse Manufacturing, Ecodesign '01*, Tokyo, December 2001, pp.864-869. (IEEE Computer Society, Los Alamitos).
- [11] Klöcker S. and Müller H., Ecological classification and risk analysis to evaluate environmental impact of new products, In *International Conference on Engineering Design ICED '99, Vol.3*, Munich, August 1999, pp.1483-1488. (Technische Universität München, Garching).
- [12] Jesper Olesen, Environmental QFD – The Creation of Project focus, In *International Conference on Engineering Design, ICED '97, Vol.1*, Tampere, August 1997, pp. 323-328.
- [13] Roche T, Development of a CAD integrated DFE Workbench tool, In *International Symposium on Electronics and the Environment*, Denver, 2001. (IEEE Computer Society, Los Alamitos).
- [14] Reiner Anderl, et. al., Life cycle modeling – a cooperative method supports experts in the entire product life cycle, In *International Conference on Engineering Design ICED '99, Vol.3*, Munich, August 1999, pp.1801-1804. (Technische Universität München, Garching).
- [15] Niki Bey, Torben Lenau, and Michael Holm Larson, Oil Points – Life Cycle Evaluations without the data problem, In *International Conference on Engineering Design ICED '99, Vol.1*, Munich, August 1999, pp.469-472. (Technische Universität München, Garching)
- [16] O wager, C Oberender, H Birkhofer and J sauer, Designing for ecological consumer use: A case study of a interdisciplinary approach to eco-effective product design, In *International Conference on Engineering Design, ICED '01, Vol.1*, Glasgow, August 2001, pp.701-708.
- [17] T Gómez-Navarro et. al., Design for energy efficiency, In *International Conference on Engineering Design, ICED '01, Vol.1*, Glasgow, August 2001, pp.613-620.
- [18] P Tonnelier, D Millet, M le Coq and P Michaud, Design for recovery – evaluation of recovery aptitude of a vehicle, In *International Conference on Engineering Design, ICED '01, Vol.1*, Glasgow, August 2001, pp.661-668. (Professional Engineering Publishing, Bury St Edmunds).
- [19] B Rosemann, H Meerkamm, St. Trautner, and K Feldmann, Design for recycling, recycling data management and optimal end-of-life planning based on recycling-graphs, In *International Conference on Engineering Design ICED '99, Vol.3*, Munich, August 1999. pp. 1471-1476.
- [20] Mario Fagnoli(s), The assessment of the Environmental Sustainability, In *Third International Symposium on Environmentally Conscious Design and Inverse Manufacturing, Ecodesign '03*, Tokyo, December 2003, pp.362-368. (IEEE, Piscataway).
- [21] V Lofthouse and T Bhamra, A creative element – Ecodesign tools for industrial design, In *International Conference on Engineering Design, ICED '01, Vol.2*, Glasgow, August 2001, pp.733-740. (Professional Engineering Publishing, Bury St Edmunds)
- [22] Mattias Lindahl, *Engineering Designers' Requirements on Design for Environment Methods and Tools*, 2005, (PhD Thesis, KTH, Stockholm).
- [23] G Pahl and W Beitz, *Engineering Design – A systematic Approach*, 1998, (Springer-Verlag).
- [24] Srinivas Kota and Amaresh Chakrabarti, Development of a method for estimating uncertainty in evaluation of Environmental Impacts during design, In *International Conference on Engineering Design, ICED '07*, Paris, August 2007.

Contact: Amaresh Chakrabarti,
 Indian Institute of Science,
 Centre for Product Design and Manufacturing,
 Indian Institute of Science, Bangalore - 560012,
 India
 Phone: +91-80-22933136
 Fax:: +91-80-23601975
 e-mail: ac123@cpdm.iisc.ernet.in
 URL: <http://cpdm.iisc.ernet.in/people/ac/ac.htm>.